

(No Model.)

P. D. NICOLS & T. W. WEBB.  
MACHINE FOR TWISTING DRILL BLANKS.

No. 245,741.

Patented Aug. 16, 1881.

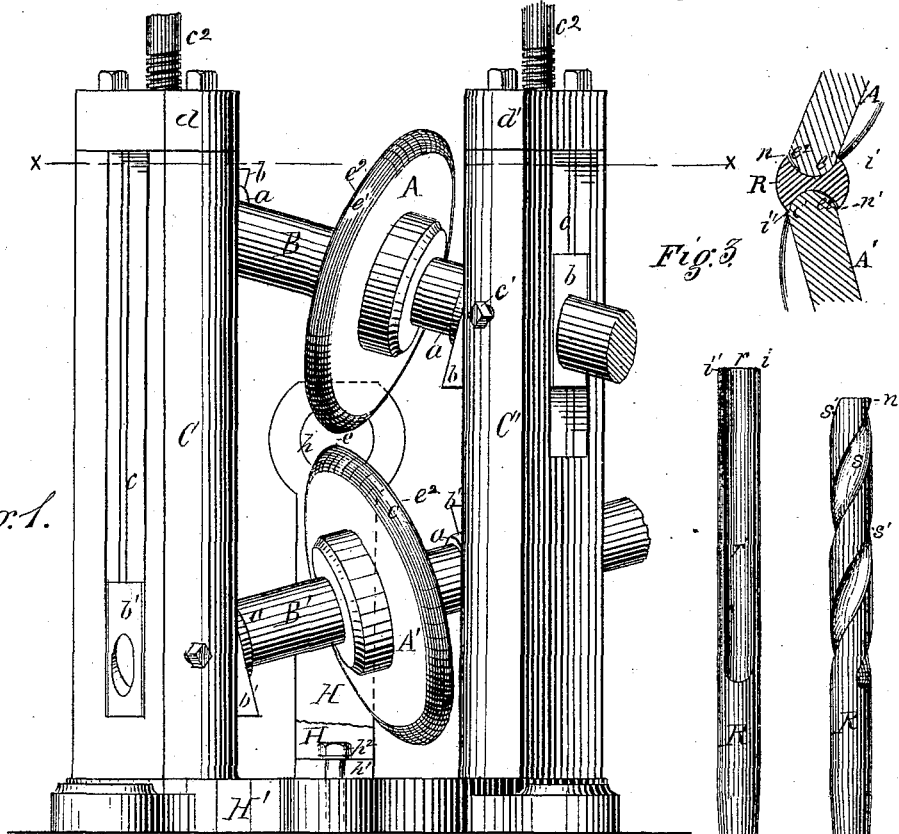

Fig. 1.

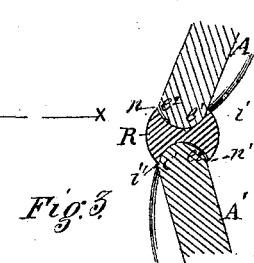

Fig. 3.

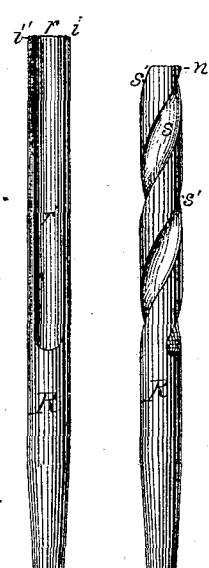

Fig. 4. Fig. 5.

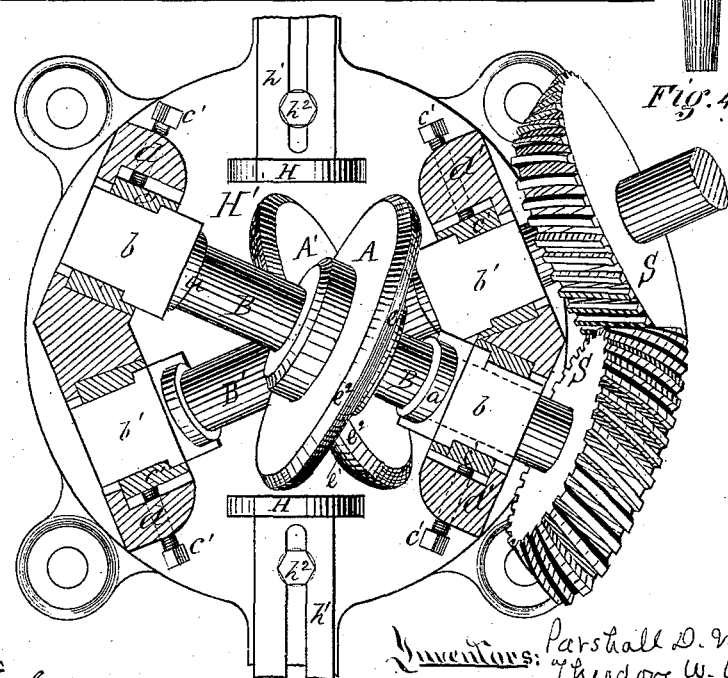

Fig. 2.

Witnessed,  
R. H. Whittlessey  
G. A. Parker

Inventors: Marshall D. Nicols,  
Theodore W. Webb.  
By Attorney George H. Phinney

# UNITED STATES PATENT OFFICE.

PARSHALL D. NICOLS, OF SEWICKLEY, AND THEODORE W. WEBB, OF  
PITTSBURG, PENNSYLVANIA.

## MACHINE FOR TWISTING DRILL-BLANKS.

SPECIFICATION forming part of Letters Patent No. 245,741, dated August 16, 1881.

Application filed February 28, 1881. (No model.)

To all whom it may concern:

Be it known that we, PARSHALL D. NICOLS, of Sewickley borough, county of Allegheny, State of Pennsylvania, and THEODORE W. WEBB, of Pittsburg, county of Allegheny, State of Pennsylvania, have invented or discovered a new and useful Improvement in Machines for Twisting Drill-Blanks; and we do hereby declare the following to be a full, clear, concise, and exact description thereof, reference being had to the accompanying drawings, making a part of this specification, in which—like letters indicating like parts—

Figure 1 shows, in side elevation, our improved machine for twisting drill-blanks and similar articles, the front guide being broken away. Fig. 2 is a sectional plan view of the same, the section of the housings being taken in the plane of the line  $xx$ , Fig. 1. Fig. 3 is a detached view of small segments of the rolls and a section of the blank, illustrative of the bearings of the rolls upon the blank; and Figs. 4 and 5 show, on a reduced scale, plain and twisted blanks, in illustration of the work done by the machine.

This invention relates to mechanism for twisting drill, auger, and similar blanks; and, in general terms, it consists of two disk-rolls adjustably mounted in housings and driven in opposite directions by gear-connections, which rolls have a peripheral bearing upon opposite sides of the blank, the direction of bearing being inclined across the line of feed in opposite directions, and the planes of the rolls being inclined in opposite directions to a horizontal plane through the line of feed; or, in other words, the rolls are inclined in opposite directions, both to vertical and horizontal planes, through the line of feed, with their centers out of and on the same side of such vertical plane.

In the drawings,  $A A'$  represent two rolls mounted upon shafts  $B B'$ , respectively. These shafts have their bearings in journal-blocks  $b b'$ , which latter are secured in vertical openings or slots  $c$ , made in the housings  $C C'$ , by means of adjusting blocks and screws  $c' c^2$ , or by other suitable and well-known means for effecting such end. The housings  $C C'$  are, by preference, made with two wings or inclined sides,  $d d'$ , which are arranged at such angle that the di-

agonally-opposite inner faces of the wings shall be parallel or nearly so. These housings may, however, have a curved or other form in horizontal section, such forms being common in the art.

The roll-shafts  $B B'$  are journaled in diagonally-opposite blocks,  $b b$  and  $b' b'$ , respectively. Thus the two shafts are crossed between housings, and the planes or peripheries of the two rolls are also crossed; also, the journal-bearings in one housing (the left-hand one, as shown) are separated vertically farther than in the other, thereby inclining the shafts and tipping or inclining the planes of the rolls in opposite directions to an intermediate horizontal plane; also, the inner faces of the blocks  $b b'$  are beveled, as shown in Fig. 1, presenting a face at or practically at right angles to their respective shafts, and collars  $a$ , bearing against such faces, prevent endwise motion of the shafts. The double inclination thus given to the rolls may be varied as desired by moving the blocks  $b b'$  vertically or laterally within the housings by means of the adjusting-screws  $c' c^2$ , thereby increasing or diminishing the inclination of the rolls either to a vertical or horizontal plane, or to both. The purpose of this double inclination will presently appear. The rolls are secured on their shafts with their centers in or nearly in the same vertical plane, and the point  $e$  of nearest approach of their peripheries is at one side of the plane of their centers. The line of feed is through this point  $e$  in a horizontal direction, bisecting the acute angles of crossing between the rolls. In order to direct the blank in such line of feed, guides  $H$ , having guide-holes  $h$  inclosing such line, are erected from the base  $H'$ , on which the housings are supported. These guides are made adjustable by slotted angle-plates  $h'$  and binding-screws  $h^2$ . Two such guides are employed, one on each side of and close to the rolls, as indicated in Figs. 1 and 2.

A blank,  $R$ , having concave channels or grooves  $r'$ , made lengthwise in its opposite sides, as illustrated in Figs. 3 and 4, is fed through the guide-holes  $h$  between the peripheries of the rolls, with the end  $r$  forward and the grooves  $r'$  above and below, as indicated in Fig. 3. The rolls being rotated in opposite

directions by suitable gearing S S, they will take a bite on the blank and feed it forward. In so doing the upper roll, A, bears downward upon the upper right-hand corner, *i*, such bearing extending backward across the blank in the direction of the spiral groove *s*, Fig. 5; also, the under roll, A', bears upward on the diagonally-opposite underedge, *i'*, of the blank, but extending backward across the blank in the direction of the under spiral groove, *s' s'*, Fig. 5. As the rolls take such bearings the shank end of the blank is held from turning by the workman, and the blank being properly heated, the grooved part will be twisted by the action of the rolls as they feed it forward, giving it the form shown in Fig. 5. When the blank has been twisted in this manner throughout the grooved part of its length the motion of the rolls is reversed, and the workman then letting the blank turn freely, it is run back and out of the rolls with a screw motion.

It will be observed that, owing to the tip of the rolls, their bearing is on the edges *e' e'*, which edges are rounded approximately to the curve of the grooves against which they bear, as in Fig. 3; also, that this bearing is against the sides of the grooves *i i'* opposite the cutting-edges *n n'*; consequently these cutting-edges are kept sharp and in proper form. Also, to provide room for the binding of the edges of the blank, the side edges, *e<sup>2</sup>*, of the rolls are beveled off or cut away in convex or rounded form, corresponding approximately to the curve of the groove on the cutting edge or side, which in drills is usually made fuller or straighter than the opposite sides, as shown in Fig. 3. By this means the sides of the blank are held between the opposite edges, *e' e<sup>2</sup>*, of the rolls, so that the same degree of bending and uniform work is at all times secured.

The pitch of the twist given by the rolls depends upon the angle of crossing and angle of inclination to a horizontal plane, and provision is made for adjusting these angles, as above described, not only to enable the workman to increase and diminish the pitch, when desired, but also to adjust the rolls and their angles of inclination for operating upon blanks of different sizes. We prefer, also, to use rolls of different sizes where the change in size of the blanks is considerable, and in this way the required range of adjustments may be obtained in comparatively small limits.

It has been stated that longitudinal feed motion is given to the blank by the action of the rolls alone, and is due to their rotary motion; also, that the power which twists the blank is imparted through the rolls, and is due to their rotary motion, in combination with their peculiar inclined arrangement. In these respects our invention differs materially from a twisting die or form through which the blank is forced, and also from those machines in which a traveling die or traveling parallel rotary disks running idle on their bearings are

used in combination with a rotation of the blank in a lathe or similar apparatus, the power which twists the blank and rotates the disks being communicated through the blank. In our improved machine the power is applied through the rolls directly upon that part of the blank to be twisted; consequently much less strain is imposed upon the blank and a more uniform and better product is secured.

Conical gear-wheels S S, having spirally-arranged cogs, as shown in Fig. 2, may be employed for driving the rolls in opposite directions, the bevel and spiral inclination of the cogs being such as to cause them to take a full bearing when in conjunction. Other suitable or desired forms of gearing may be employed, however.

The rolls may be driven from either shaft B or B' by any desired means of applying power; and any suitable or convenient means for reversing motion may be employed, as by straight and crossed belts or otherwise. Such appliances being in common use in machinery, they need not be described particularly.

The blank R here shown, and the method or means of forming it, constitute the subject-matter of a separate invention and application for patent; but, so far as it relates to the present invention, such blank may be formed in any of the ways known in the art; and instead of drill-blanks, auger-blanks and other similar articles may be twisted as herein described. The forms of such blanks and the methods of producing them are well known in the art.

We have shown and described two housings, C C', with the shafts B B' crossed between them in a plane nearest the right-hand housing and the line of feed in the central line between housings. These details of construction are not material, however, as the shafts may be crossed at other points in their length and the line of feed be shifted thereby, which occurs to a greater or less extent in making the adjustments above described; also, one housing only may be used with long bearings for the shafts, or the shafts may be set in such relations that the rolls may be carried on their extended ends outside of one or the other of the housings, as preferred, the rolls having the same relative arrangement, inclination, and operation as herein shown and described. These and similar modifications in the details of construction we consider as coming within our invention.

We do not claim as our joint invention rolls or rolling-dies similar to those herein described, except when such dies have axes of motion which are doubly inclined with relation to each other, as above described, as similar rolling-dies having axes inclined in one direction, whereby the peripheries of the dies are made to bear obliquely across the line of feed, are the separate invention of one of these applicants, Theodore W. Webb, and form, in part, the subject-matter of a separate application for patent by him.

We claim herein as our invention—

1. In a machine for twisting drill and similar blanks, the combination of two rolls arranged to take a peripheral bearing on opposite sides of the blank, such rolls being inclined in opposite directions to both vertical and horizontal planes through their line of feed, and gear mechanism for imparting to the rolls rotary motion in opposite directions, substantially as set forth.

2. Two rolls, A A', arranged to take a peripheral bearing on opposite sides of a blank, the directions of such bearing being inclined across the line of feed in opposite directions, and the rolls being inclined in opposite directions to an intermediate horizontal plane, in combination with guides H on either side of the rolls in the line of feed, and means for giving to the rolls rotary motion in opposite directions, substantially as set forth.

3. In a machine for twisting drill, auger, and

similar blanks, the combination of two rolls, A A', arranged to take a peripheral bearing on opposite sides of the blank, such rolls being inclined to both vertical and horizontal planes through the line of feed, with their centers out of and on the same side of such vertical plane, and having the bearing-edges  $e' e'$  of their peripheries rounded and the free edges  $e^2 e^2$  cut away, as described, with means for varying the angles of inclination of the rolls, adjustable guides H, and means for giving the rolls rotary motion in opposite directions, substantially as and for the purposes set forth.

In testimony whereof we have hereunto set our hands.

PARSHALL D. NICOLS.  
THEODORE W. WEBB.

Witnesses:

C. L. PARKER,  
R. H. WHITTLESEY.